

TUFGRIP™ DUAL WEDGE®

SERIES 1500

FOR PVC, DUCTILE AND HDPE PIPE

A Proven Third-Generation Mechanical Joint Restraint

Tyler Union’s TUFGrip™ restraint represents the culmination of 20 years of engineering and testing. As a third generation restraint, TUFGrip is the best available technology in the waterworks market for use in restraining PVC, ductile and HDPE pipe.



FEATURES & ADVANTAGES

- Torque limiting nut on gripping wedge assembly twists off within a designed torque range-eliminating the need for specialized tools.
- Gripping wedge assembly pivots providing stronger engagement of pipe wall at lower torque requirement (45–60 ft-lb).
- Proven restraint technology utilizing fewer gripping wedges in frequently applied diameters, reducing trench time and project cost.
- Restraint’s heavy duty construction and design eliminates the need for costly thrust blocks and tie rods.
- Approved for use on multiple classes of pipe — Pressure ratings and associated pipe classes provided on the following pages.
- Suitable for potable and wastewater applications.
- Controlled wedge contour to accommodate contact circumference when assembled on different types of pipe.

SPECIFICATIONS

- Designed to restrain plain end PVC, ductile iron and HDPE pipe.
****Note:** IPS diameter pipe requires the use of an MJ Transition gasket. Ductile iron pipe conforming to ANSI/AWWA C151/A21.51 in diameters 3” thru 24” with a maximum surface hardness value of 250 Brinell at the engagement point of the wedges. (ISO 2531 for Ductile Iron Pipe specifies a maximum harness value of 230 Brinell)
- Restraint design conforms with applicable requirements of ANSI/ AWWA C111, ANSI/AWWA C153 and ANSI/AWWA C110.
- Restraint engineered for securing plain end pipe to Mechanical joint fittings conforming to ANSI/AWWA C110, C111 and C153.
- Cast of ASTM A536 compliant 65-45-12 ductile iron complete with a cast on date code and country of origin for traceability.
- Restraints and all components are designed and proven for a 2:1 safety factor based on the pipe pressure rating.
- Restraint deflection rating when installed on nominal diameter pipe: 3° max for 4”–12”, 2° max for 14”–16”, and 1.5° max for 18”–24”.
- Standard coating for Non-Domestic restraint is 4–6 mil of TUF-Bond™ (thermoset polyester for impact, corrosion and UV protection).
- Gripping wedges are heat treated to a minimum 420 Brinell Hardness .
- Gripping wedge, wedge collar bolt and twist off torque limiting nut shall be e-coated.
- FM approved for 4”–16” applications and UL listed and approved for 4”– 24” applications.
- Not recommended for use on plain end fittings.
- Color coded orange for use on multiple classes of pipe and to distinguish from traditional restraints.

ISO 9001-2015 Registered	Listed with Underwriters Laboratory	Factory Mutual Approved
--------------------------	-------------------------------------	-------------------------

Product Source/Type	Name of Project	Name of Contractor	Project Engineer	Spec. Section and/or Project No.

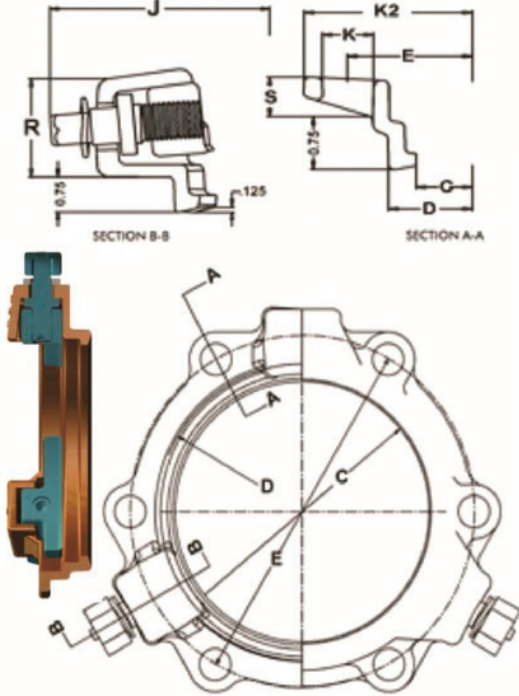

TUFGRIP™ MJ Restraint Dimensions								
Size (In.)	C	D	E	K2	J	K	R	S
4	4.93	5.92	7.50	8.98	10.67	7/8	2.20	0.73
6	7.03	8.02	9.50	10.98	12.77	7/8	2.24	0.82
8	9.18	10.17	11.75	13.23	14.92	7/8	2.28	0.82
10	11.23	12.22	14.00	15.70	16.97	7/8	2.37	0.93
12	13.33	14.32	16.25	17.95	19.07	7/8	2.40	0.93
14	15.44	16.40	18.75	20.43	21.18	7/8	2.57	0.91
16	17.54	18.50	21.00	22.88	23.28	7/8	2.7	1.05
18	19.64	20.60	23.25	25.43	25.38	7/8	2.57	1.05
20	21.74	22.70	25.50	27.50	27.48	7/8	2.66	1.15
24	25.94	26.90	30.00	32.00	31.68	7/8	2.72	1.35
30	32.18	33.30	36.88	39.42	39.78	1-1/8	3.86	1.53
36	38.48	39.60	43.75	46.29	46.08	1-1/8	3.86	1.53
42	44.68	45.80	50.62	53.62	53.08	1-3/8	4.56	2.05
48	50.98	52.10	57.50	60.50	59.28	1-3/8	4.56	2.05

SERIES 1500 TDW — TUFGRIP™ — APPLICATION CHART

Size (In.)	Part # – Gland Only Non-Domestic	Wedge Qty.	T-head Bolt Qty.	Bolt Size	Gland weight (lbs.)	Weight (w/Acc.)	DI Pipe	C-900 C-905	Pipe O.D.
4	602000	2	4	3/4" x 3-1/2"	7.1	11.8	350	*305/DR14	4.80
6	602005	3	6	3/4" x 4"	11.2	18.8	350	*305/DR14	6.90
8	602010	3	6	3/4" x 4"	13.1	20.3	350	*305/DR14	9.05
10	602015	6	8	3/4" x 4"	26.0	32.5	350	*305/DR14	11.10
12	602020	8	8	3/4" x 4"	31.5	40.4	350	*305/DR14	13.20
14	602025	10	10	3/4" x 4-1/2"	43.3	53.6	350	*235/DR18	15.30
16	602030	12	12	3/4" x 4-1/2"	54.1	66.3	350	*235/DR18	17.40
18	602035	12	12	3/4" x 4-1/2"	59.8	72.2	250	*235/DR25	19.50
20	602040	14	14	3/4" x 4-1/2"	69.8	83.8	250	*235/DR25	21.60
24	602045	16	16	3/4" x 5"	90.4	106.9	250	*235/DR25	25.80

NOTE: The pressure ratings are rated working water pressure for the restraint. See page 3 for additional ratings.

ISO 9001-2015 Registered	Listed with Underwriters Laboratory	Factory Mutual Approved
---------------------------------	--	--------------------------------

STOP-LOOK:

- For approvals, 4"–12" were tested at 3° of deflection, 14"–16" were tested at 2° of deflection and 18"–24" were tested at 1.5° of deflection; 4"–16" inch tests were to 700 psi and 18"–24" tests were to 500 psi.
- The Series 1500 TUFGRIP is specified for use on PVC, ductile and HDPE Pipe, but can be used on some sizes of cast grey iron or pit cast pipe if the pipe is not severely corroded, is in sound condition and has an outside diameter compatible with the as provided dimensions.
- Installation and hydrostatic testing shall be in accordance with AWWA C600 and AWWA C651.

****SERIES 1500 TDW-TUF GRIP™ RESTRAINT RATINGS**

Size (In.)	Ductile Pipe	AWWA C900			AWWA C905			AWWA C909	ASTM D2241			HDPE* AWWA C906				
	C151/A21.51	DR14	DR18	DR25	DR18	DR25	DR32.5		SDR17	SDR21	SDR26	DR7.3	DR9	DR11	DR13.5	DR17
4	350	305	235	165	-	-	-	235/150*	250	200	160	254	200	160	128	100
6	350	305	235	165	-	-	-	235/150*	250	200	160	254	200	160	128	100
8	350	305	235	165	-	-	-	235/150*	250	200	160	254	200	160	128	100
10	350	305	235	165	-	-	-	235/150*	250	200	160	254	200	160	128	100
12	350	305	235	165	-	-	-	235/150*	250	200	160	254	200	160	128	100
14	350	-	-	-	235	165	125	-	-	-	-	254	200	160	128	100
16	350	-	-	-	235	165	125	-	-	-	-	254	200	160	128	100
18	250	-	-	-	200	165	125	-	-	-	-	-	-	-	-	-
20	250	-	-	-	200	165	125	-	-	-	-	-	-	-	-	-
24	250	-	-	-	165	165	125	-	-	-	-	-	-	-	-	-

NOTE: Pressure ratings for ordinary water works restraint applications with transitory surges only.
NOTE: AWWA C909 PVC0 restraint pressure rating is per the pressure.
NOTE: HDPE applications require a separate stiffener ring, 4"-16" for DI OD Pipe and 4"-12" for IPS OD pipe rating listed on the pipe.



STEP 1 & 2



STEP 3

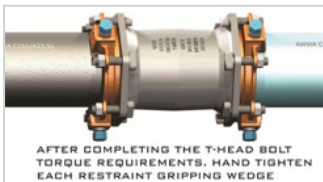

STEP 4 & 5

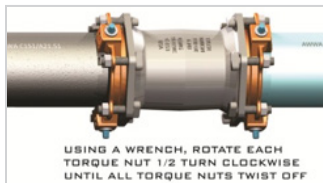

STEP 6 & 7

INSTALLATION

1. Ensure the beveled pipe end to be joined and mechanical joint socket are clean and free of debris. Slide the orange TUFGrip onto the beveled end of the pipe to be restrained. The TUFGrip compression lip extension must be toward the beveled end of the pipe being restrained.
2. Evenly lubricate the beveled pipe end, exterior pipe wall and inside surface of the gasket with a lubricant that meets the requirements of AWWA C111. Now place the **MJ gasket over the plain beveled end of the pipe with the narrow edge of the tapered gasket toward the pipe end. ****NOTE:** Use MJ transition gasket with IPS diameter pipe.
3. Fully insert the beveled pipe end into the MJ socket pipe landing. Keeping the pipe straight in the MJ socket, slide/push the MJ gasket firmly and evenly into the MJ socket recess. Joint must be kept straight during assembly.
4. Push the TUFGrip compression lip extension evenly against the thick side of the MJ gasket and insert all T-head bolts with nuts. Use only T-head bolts and nuts that meet AWWA C111 requirements. With the TUFGrip restraint lip extension against the MJ gasket, evenly hand-tighten the nuts on the T-head bolts making sure the restraint body is centered on the pipe and within the MJ socket. If joint deflection is needed, deflect the pipe only after hand tightening of all nuts is completed. Joint deflection is 3° max for 4"-12", 2° max for 14"-16", 1.5° max for 18"-24". **NOTE:** Maximum deflection values provided apply with nominal pipe, fitting and restraint diameters.
5. Using a wrench, tighten the T-head bolts and nuts a few turns at a time in an alternating or star pattern. Maintain equal spacing or distance between the TUFGrip bolt flange and the MJ socket bolt flange as the MJ gasket is compressed. Repeat the process in an alternating pattern for all T-head bolts and nuts. The T-head bolt and nut torque requirement is 75-90 ft-lb for 4"-24".
6. **NOTE:** The C909 PVC0 T-head bolt and nut torque is 55-65 ft-lb for 4"-8" and 65-75 ft-lb for 10"-12" restraints. **DO NOT OVER-TORQUE T-HEAD BOLTS and NUTS WHEN ASSEMBLING PVC and PVC0 PIPE!**
7. ****Hand-tighten** the torque limiting nuts attached to the TUFGrip wedge assemblies in a clockwise direction with an alternating or star pattern until all gripping wedges are in contact with the pipe wall. Rotational direction of torque nut is indicated by recessed arrow on the face of the nut. With a wrench (box, socket or pneumatic), continue to tighten each torque nut half turn in an alternating or star pattern around the restraint until all torque limiting nuts twist off. **NEVER** turn a torque limiting nut more than half turn without turning the remaining torque nuts an equal amount! ****NOTE:** For IPS and PVC0 applications, ensure step 5 is completed before engaging wedges. Failure to comply will result in excessive pipe wall deflection and torque nuts will not twist off as designed.
8. When all torque limiting nuts twist off, the mechanical joint and restraint assembly are complete.